

Islanding Detection of IEEE 13 Bus System Based on Sequence Components

P. Prudvi Raj*

Abstract: Islanding recognition in microgrids is crucial for enhancing power system safety and efficiency. This article presents a novel passive islanding recognition technique for grid integrated renewable Distributed Generation (DG) network. This approach is based on current and voltage disturbances at the moment of islanding. The islanding recognition method is based on the sequence analyzers connected with the point of common coupling (PCC). The suggested method is suitable for estimating the islanding situation in a 0% active power mismatch. The system created in this islanding work is a perfect 13 bus system. It has been tested for a variety of non-islanding circumstances. A microgrid network is simulated using the MATLAB R2016a software.

Keywords: Islanding detection, Non detection zone, Micro grid, Fault analysis, Power quality.

1. Introduction

With rising electricity consumption as well as a desire to keep our nature clean, sustainable power distributed generating is becoming more widespread. There are more issues as the number of distributed generating systems based on renewable power sources are increasing. Connecting these DG towards the traditional grid presents several issues in maintaining the existing power system's health and security. Because electricity now flows from both ends of a microgrid, islanding recognition is one of the primary challenges [1]. The term "microgrid islanding" refers to a case in which the main grid is unavailable due to faults or disruptions and the distributed energy sources are exclusively responsible [2]. According to IEEE STANDARD 1547- 2018, distributed generators detect the islanding state and form an island within 2 seconds.

Many researches have been proposed some techniques on islanding so far. In this islanding, there are some techniques namely, 1) Active techniques, 2) Passive technique 3) communication-based technique and 4) hybrid technique. In passive technique, electrical parameters or quantities derived from the electrical quantities will be continuously monitored to identify the islanding condition. In Active technique, inject a signal into the system using inverter controllers and examine the behavior of the electrical parameters at the islanding instant [3]. It employs positive feedback techniques that cause the islanded system to enter an unstable state and trip UVR/OVR or UFR/OFR at the islanding moment. In communication, we will use software-based techniques involved with SCADA, PLC to monitor circuit breakers [4]. In Hybrid islanding recognition, it is the combination of passive and active methods. Which observer that we can handle the technique in active and passive this will helps more in the islanding. In this paper we will follow the method which is SEQUENCE ANALYZERS i.e., By analyzing the both positive and negative sequence of the parameters which are mainly voltage and current [5]. In this technique we will observe the disturbance at the grid side by giving some faults. With those disturbances we will find the islanding mode in the system. This voltage disturbance is observed at the PCC.

Article History

Received: 10-03-2023;

Revised: 15-05-2023;

Accepted: 25-05-2023

*Corresponding author: Department of Computer Science, Auburn University at Montgomery, Montgomery, AL 36117, United States

E-Mail: prudhviraj61396@gmail.com

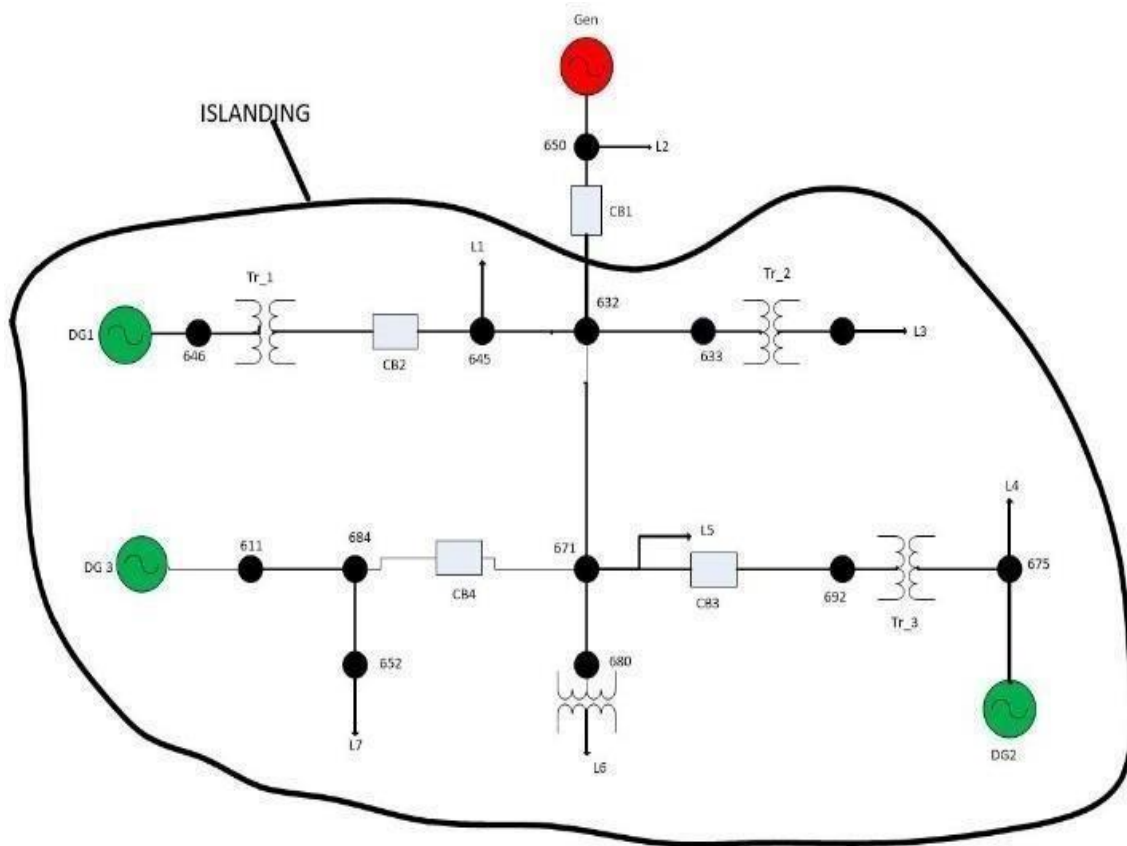

Fig.1: Suggested test system for proposed islanding recognition

This PCC is the point at which both the grid and DGs are connected. As illustrated in Fig.1, the circuit diagram of the network being monitored is simulated in MATLAB R2022b [6]. Three variable PV- based distributed generators with ratings of 100kv, 150kv, and 250kV are linked to a 23 kV distribution system through a 0.380/25 kV transformer. The frequency of the system is 50 hertz. The three-phase voltage and three phase current samples are taken at 2 seconds of time intervals. The phenomenon of islanding happens when a component of the power system gets electrically isolated from the main grid while continuing to generate and use electricity. This can put utility personnel and the general public in risk since it can cause a breakdown of synchronization between the islanded system and the main grid, resulting in power quality concerns or even blackouts. As a result, detecting islanding occurrences in power systems is critical for ensuring system stability and dependability. Many studies and research articles have been published on the issue of islanding detection in power systems. They encompass a wide

range of techniques and methodologies and include both analytical and experimental approaches. Among the important scientific publications and studies on this subject are: The technique proposed in this paper is MOVDACD which is applied in the 3-bus power system. This will detect the islanding in the power system with a very low disturbance, which is applicable at very less conditions. The graphs are slightly incorrect and we are rectified this to cover the high- power system so we used a perfect 13-bus system and we will obtain the graphs with some accurate values in the system [7] An islanding recognition technique for inverter connected DG is suggested based on voltage magnitude variation. This will help us on how to do the islanding in the power system. This will find islanding with zero non-detection zone (NDZ), little consequence on power quality and less output. In this paper islanding will do with help of reactive power mismatch. From this paper, we can get the information about how islanding has occurred with reactive power; we can do islanding with active power in this system [8]. Using

the Second Generation Wavelet Transform (SGWT) and the Maximum Overlap Discrete Wavelet Transform (MODWT), an effective passive islanding recognition strategy for a grid integrated hybrid DG system has been suggested. The harmonic strength of the voltage signal is detected at the PCC and monitored by signal decomposition using SGWT and MODWT techniques up to acceptable finer levels in this methodology. This will help us understand how the system's islanding happens [9]. The power quality aspect of the modified sliding mode controller as a novel active IDM for grid-connected solar systems (GCPVS) with a string inverter will be investigated. Its performance is compared to that of a well-known active IDM, the voltage positive feedback (VPF) approach. With the aid of this work [10], we may investigate one of the ways for identifying islanding in power systems. Using modified empirical mode decomposition (MOEMD), a time-domain passive islanding detection approach for a grid-connected hybrid distributed generating system has been created. The MOEMD decomposes the point of common coupling voltage into numerous oscillatory components known as intrinsic mode function in this work we may examine islanding approach in power system [11]. The detection of islanding requires a fresh focus on advanced signal processing technologies. The suggested approach is based on Ensemble Empirical Mode Decomposition (EEMD), in which Gaussian white noise is introduced to the original signal, solving the mode mixing problem of Empirical mode decomposition (EMD), and the Hilbert transform is used to get Intrinsic mode functions (IMF). This research will help us comprehend the novel islanding strategy in power systems [12]. This paper is organized as follows: Section 2 The Proposed Islanding Detection Technique of ISD. The Description of the Islanding Detection Technique and Proposed Method of the Technique. Result and Discussions Conclusion of the Islanding cases and Non-Islanding cases. Finally at last conclusion and future scope.

2. Test system and Proposed method

The technique proposed uses Sequence analyzers at the PCC and at the targeted DG location for the islanding identification. Here the Voltage disturbances is written as

$$VD = V_2 / V_1 \quad (1)$$

where V_2 and V_1 are NS (Negative Sequence) and PS (Positive Sequence) components of voltage respectively. As well as Current Disturbances is defined as

$$CD = I_2 / I_1 \quad (2)$$

I_2 and I_1 are the NS and PS i.e., Negative Sequence and Positive Sequence of Current respectively. With the use of current and voltage phasors, these symmetrical numbers are created. Data for three phase of voltages and the three-phase current during both non-islanding and islanding conditions are attained. Voltages and current are phasor estimated before their symmetric components are determined. To recognize the islanding case, Sequence analysis is used;

$$\text{Islanding Detection Signal (ISD)} = | V_2 / V_1 * I_2 / I_1 | \quad (3)$$

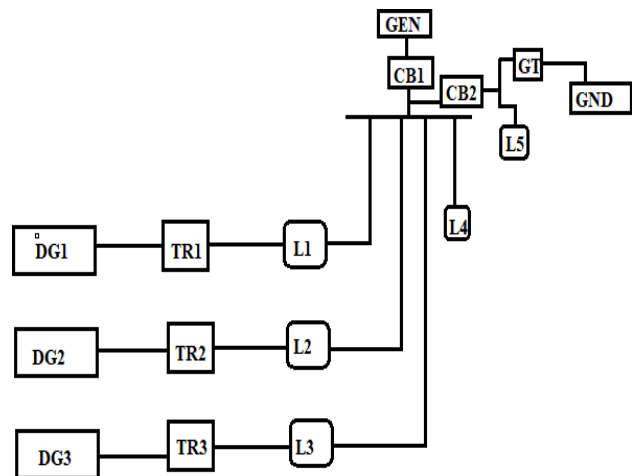

Fig.2: Block diagram for proposed system

3. Proposed islanding detection method

A minimal threshold of 0.001 is exceeded by sequence analyzer during the islanding condition. Based on the Sequence Analysis value, the islanding and the non-islanding conditions are found. The key role in this project is sequence analyzers and the sequence analyzers are Another important task in sequence analysis is phylogenetic analysis, which involves constructing evolutionary trees based on sequence data [5]. MATLAB provides functions for constructing phylogenetic trees based on different methods such as maximum likelihood or Bayesian

inference. These trees can be used to infer evolutionary relationships between sequences and to identify homologous sequences across different species. Sequence motif discovery is another important task in sequence analysis, which involves identifying short, conserved regions within a larger sequence that may be important for protein function. MATLAB provides functions for identifying sequence motifs, which can be used to identify motifs specific to certain protein families or involved in specific biological processes. Finally, gene expression analysis is another important application of sequence analyzers in MATLAB.

MATLAB provides functions for analyzing gene expression data, which can be used to identify differentially expressed genes and to identify patterns of gene expression across different conditions. Overall, MATLAB provides a powerful platform for sequence analysis, allowing researchers to perform a wide range of sequence analysis tasks and gain insights into the function and evolution of biological sequences. Creating evolutionary trees using sequence data is a key component of phylogenetic analysis, another crucial step in sequence analysis. Phylogenetic trees can be built using MATLAB's functions based on a variety of techniques, including maximum likelihood and Bayesian inference. These trees can detect homologous sequences between different species and infer the evolutionary relationships between sequences. Another crucial step in sequence analysis is the discovery of sequence motifs, which entails finding brief, conserved sections within a longer sequence that might be crucial for protein function. Sequence motif identification functions in MATLAB can be used to locate motifs unique to particular protein families or engaged in particular biological processes. The measurement of gene expression is another crucial use for MATLAB's sequence analyzers. Genes that are differentially expressed can be found using MATLAB's functions for gene expression data analysis, which can also be used to find patterns of gene expression under various settings. Overall, MATLAB offers a robust framework for sequence analysis that enables researchers to carry out a variety of analysis tasks and learn more about the evolution and function of biological sequences.

Here the IEEE 13-bus model having the conventional methods and also overcome the demerits. The test results showed the method correctly in DG loadings after islanding occurs. Then the system gave the constant output without any errors or mismatches in power and voltage. Fig. 3 shows the proposed algorithm for the Sequence analysis approach. Three-phase voltage and current measurements are made at the required place with a 1 MS sampling time interval [6]. The voltage and current phasors are used for Sequence analysis assessment to determine the symmetrical components of voltage and current. The islanding condition is recognized when the sequence analyzer value rises above the negligible threshold of 0.001. According to the flowchart the method has followed and the islanding occurs from the threshold value of 0.001.

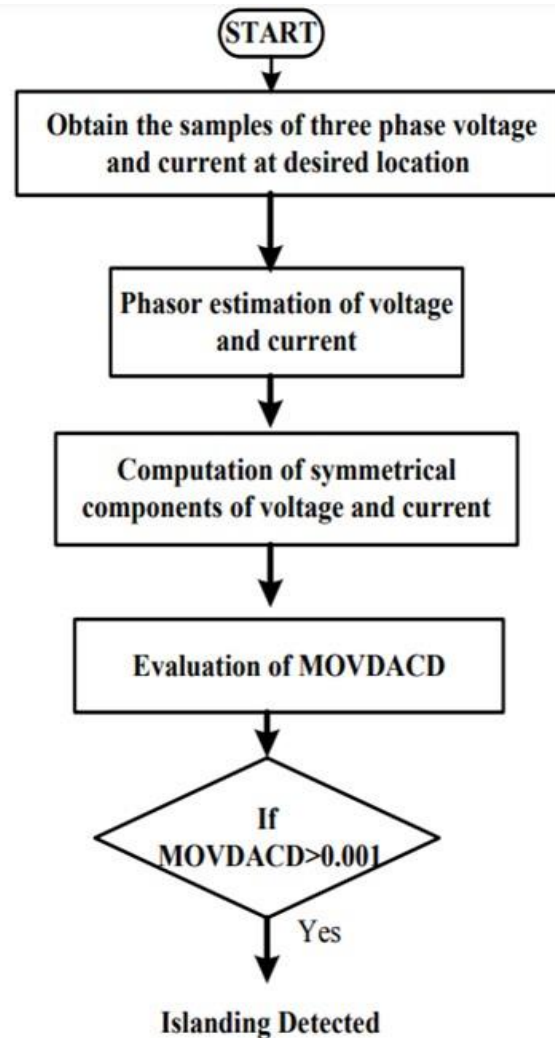

Fig. 3: Block Diagram of the Proposed system

4. Results and Discussion

4.1 Islanding cases

For 2 seconds, the simulation model is executed. By tripping the relay of circuit breaker (CB1) at 0.6s with 50% active power, the islanding situation is initiated mismatch. At PCC, data on three-phase voltage and current are gathered. NS and PS voltage and current are estimated from the three-phase and three-phase current phasors. Sequence analyzer value is less than the threshold for non-islanding conditions and more than the threshold for islanding needs. An islanding state is detected as soon as Sequence analyzer value exceeds the predetermined threshold. Fig. 4 depicts the Sequence analysis approach being used at PCC. The simulated model is run for 2 seconds. The islanding situation is started by tripping the circuit breaker (CB1) relay at 0.8 s with 0% active power mismatch. Three-phase voltage and current measurements are collected at PCC. The three-phase voltage and three phase current phasors are used to estimate the NS and PS voltages and currents. When there are no islands, Sequence analysis value is below the threshold; when there are islands, it is above the threshold. An islanding situation is detected as soon as Sequence analysis value reaches the preset threshold. The Sequence analysis technique employed at PCC is shown in Fig.5.

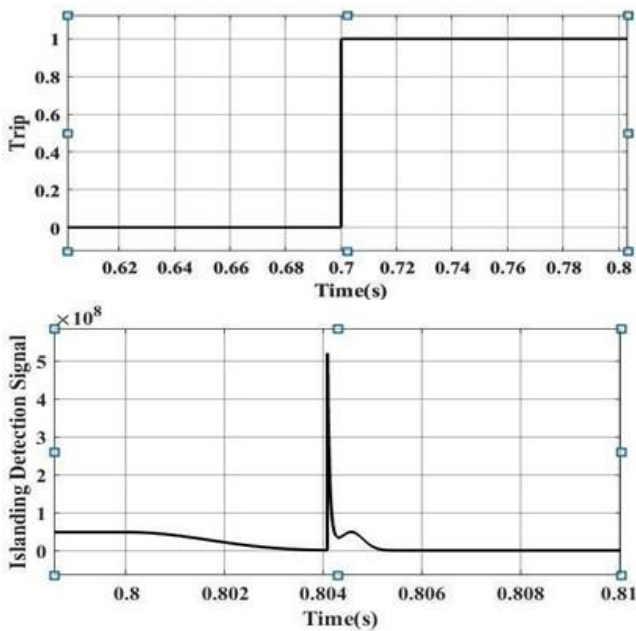

Fig. 4: Sequence analyzer technique at PCC during islanding with 50% mismatch of active power.

The three-phase voltage and three phase current phasors are used to estimate the NS and PS voltages and currents. When there are no islands, Sequence analysis value is below the threshold; when there are islands, it is above the threshold. As soon as Sequence analysis value reaches the preset threshold, an islanding situation is detected.

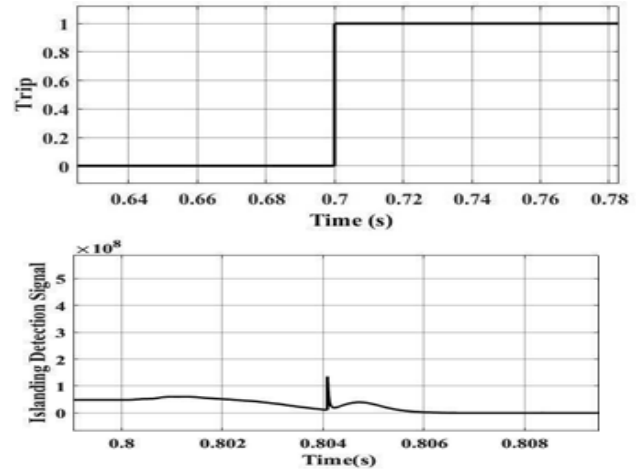

Fig. 5: Sequence analyzer technique at PCC during islanding with 0 % mismatch of active power

The above two conditions are only observed with Zero and fifty percent power mismatch. In this project, the circuit is connected with the circuit breakers to clear the fault. When we are cleared the fault, then the graphs will be changes with the cleared responsibility we can see in the following graphs

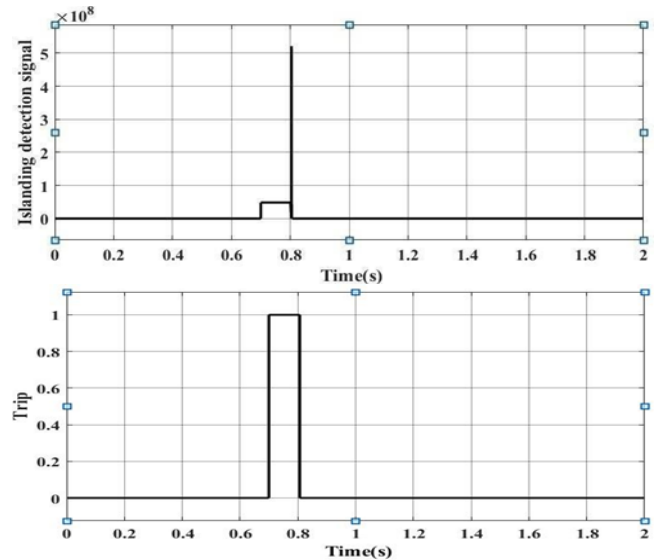

Fig. 6: Sequence analyzer technique at PCC during islanding with 0% mismatch of active power with clearing of the faults

The above two conditions are only observed with Zero and fifty percent power mismatch. In this project, the circuit is connected with the circuit breakers to clear the fault. When we are cleared the fault, the graphs will change with the cleared fault we can see in the following graphs.

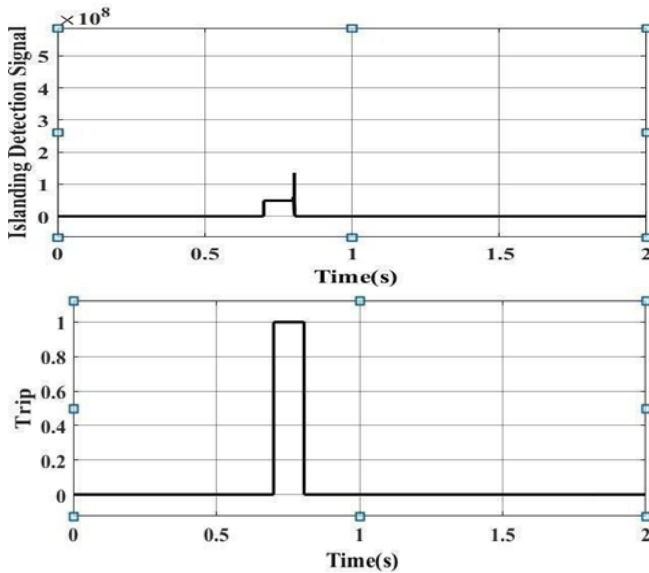

Fig. 7: Sequence analyzer technique at PCC during islanding with 50 % mismatch of active power after clearing the fault

The above two conditions will help in studying islanding detection, in extension with this the condition after the fault clearance. This study of graphs will show as that the graphs of with fifty percentage power mismatch and zero percent mismatch, i.e., the graph of fifty percent mismatch is comparatively half of the graph of zero percent mismatch which means the graph of ISD signal will be changes because of change in load. In zero percent power mismatch, The ISD graph is constant at initial condition, when the fault is occur at a particular time interval which we are given with the step signal. Then the fault is occurred in the system. Firstly, the graph will be constant after the disturbance caused by fault, this time interval will causes some disturbance and disturbance can be cleared by opening the circuit breaker at the portion the fault is occurring, then the fault will be cleared in the system and the graph will become constant. This was happened in the fifty percent power mismatch, the graph disturbance occurred is in small range and the graph is same as the previous one with small changes.

The graphs are obtained are collected with the help of scopes connected with the sequence analyzers. These are helps in studying the characteristics of the system. This can be observed in the above graphs of the Simulink model's zero and fifty percent power mismatch. These graphs give information about the situation in the fault conditions and after-fault conditions in the Simulink model. The above cases are discussed about the islanding condition; we also have to see the non-islanding zone. In this study of non-islanding zone we can observe in three different cases. After designing of the circuit, we are completed the study on islanding, we have to apply the following two conditions.

Firstly, we have to take the whole simulation model, then the non-islanding zone is created by separating of any two DGs except first DGs as we are performing the proposed technique on first DG. In this case we are cutting the DG3 completely out at 0.6 sec. After performing the proposed technique at DG1 location. During this first condition we observe the straight line in the graph without any disturbance. The non islanding condition can be observed in the figure 5(a). Similarly, In the second case, we will connect some three- phase fault is connected at the PCC. We will create fault at 0.8 sec. we will modify this circuit with two changes in this condition one is fault will be connected to PCC and second one is we are connecting the Circuit breaker at DG1 which is labeled as CB_DG1 and it will maintained closed throughout the simulation because Sequence analyzer value remain below the threshold value. Performance of the Sequence analyzer technique is shown in fig. 5(b). In 5(b) we will observe the ISD (Islanding Detection Signal) which we can see that there will be no disturbance in the system after the fault is occurred, we can see that there a sudden rise in the graph of Sequence analyzer signal we can observe this in 5(b) when we observe the trip signal in another scope, we can see that until the fault is happened there is no change in the trip signal graph once we given fault signal to the graph we can see that there is a sudden rise without any delay i.e., there is a sudden rise which looks like a straight line after that trip signal have been rise we can see that there will be no change in the graphs which means the graph of trip signal during the condition will not change.

4.2 Non islanding cases

These two cases can be observed for non-islanding condition. The graphs will be constant without any disturbance because we are studying the non-islanding zone of the circuit and the graph will be constant and the output can be verified as the non-islanding zone in the power system. Until this we are studied about the islanding, but we have to study about the non-islanding condition also. When we are studying the non-islanding condition we have some ways to study, here we will study about the non-islanding condition in two ways.

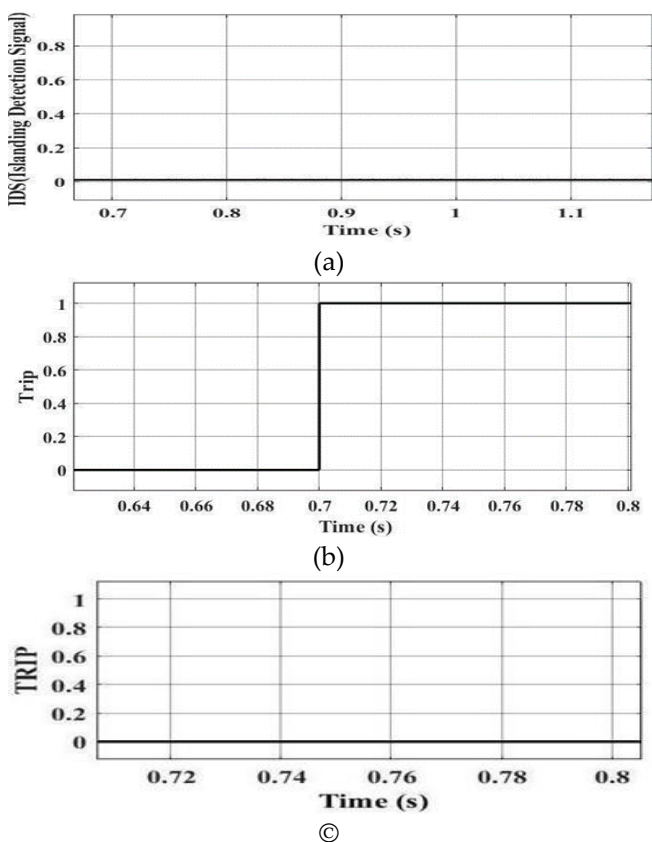

Fig. 8: Sequence analyzer technique at (a) PCC during capacitor switching (b) DG1 with DG3 section completely out and (c) DG1 during high resistance A-G fault at PCC.

Firstly, we have to take the whole simulation model, then non-islanding zone is created by separating any of the two DGs except DG1 which means we have to separate the DG3. By cutting the DG3 completely out at 0.6sec. After performing the suggested method at DG1 location. This simulation model will be observed in then following circuit. Here

the DG will be the high resistance in the A-G fault at PCC then the trip will be constant and the main thing will be the current and voltages will be constant in that moment and mainly it will be the constant system while again performing the islanding detection. The above conditions will help us in studying the non-islanding zone of the power system. The system will help us to see that the whole system will work properly. As the whole system will not completely be islanded or non-islanded in the system.

5. Conclusion

This research presents a passive islanding estimation strategy based on the current and voltage disturbance at the target site. It is discovered that the planned approach works effectively at the 0% active power imbalance. The recognition can be performed as soon as the island situation exists. The suggested technique's stability is validated under various non-islanding scenarios, and it is discovered that the relay does not trip needlessly. Whilst the suggested approach functions well under non-islanding situations, it requires a very sensitive relay to trip the distributed generator since it must detect a little deviation from zero. This project can detect the islanding in the power system circuits. The most important aspect of this project is the technique we are following for the detection of islanding. This project is worked with a perfect thirteen bus system and we followed the sequence components technique. As a result, we can detect the islanding at an advance stage of disturbances i.e., at a low level of disturbances which will prevent the damage in the power system. This project may be carried out with a different technique for detecting islanding in the power system.

Acknowledgment

The authors would like to thank the Department of Computer Science, Auburn University at Montgomery, Montgomery, AL 36117, United States for providing the necessary facilities to carry out this research work

Conflict of Interest

The authors declare, "No conflict of interest"

References

- [1] L. Canbing, C. Cao, Y. Cao, Y. Kuang, L. Zeng, and B. Fang "A review of islanding detection methods for microgrid", *Renewable and Sustainable Energy Reviews*, Vol. 35, pp. 211-220, 2014.
- [2] K. Aziah, H. Shareef, E. Bizkevelci and Tamer Khatib "A review of islanding detection techniques for renewable distributed generation systems", *Renewable and sustainable energy reviews*, Vol. 28, pp. 483-493, 2013.
- [3] M. Pukar, Z. Chen and B. B. Jensen "Review of islanding detection methods for distributed generation", *In 2008 third international conference on electric utility deregulation and restructuring and power technologies*, pp. 2743-2748, 2008.
- [4] K. M. Sung, R. Haider, G. J. Cho, C. H. Kim, C. Y. Won and J. S. Chai "Comprehensive review of islanding detection methods for distributed generation systems", *Energies*, Vol. 12, No. 5, art.no. 837, 2019.
- [5] A. K. N. E. Ku, J. Selvaraj and N. A. Rahim "A review of the islanding detection methods in grid-connected PV inverters", *Renewable and Sustainable Energy Reviews*, Vol. 13, 756-766, 2013.
- [6] R. C. Rami, B. S. Goud, B. N. Reddy, M. Pratyusha, C. V. V. Kumar and R. Rekha "Review of islanding detection parameters in smart grids", *International Conference on Smart Grid*, pp. 78-89, 2020.
- [7] B. K. Panigrahi, A. Bhuyan, J. Shukla, P. K. Ray, and S. Pati "A comprehensive review on intelligent islanding detection techniques for renewable energy integrated power system", *International Journal of Energy Research*, Vol. 45, No. 10, pp. 14085-14116, 2021.
- [8] S. Haidar, F. Hashemi and T. Ghanbari. "Minimum non detection zone for islanding detection using an optimal Artificial Neural Network algorithm based on PSO", *Renewable and Sustainable Energy Reviews*, Vol. 52, pp. 1-18, 2015.
- [9] N. Kianoush, K. Ahmed and C. Booth "A comprehensive review of islanding detection methods for distribution systems", *In 2020 9th International Conference on Renewable Energy Research and Application*, pp. 428-433, 2020.
- [10] B. K. Chaitanya, A. Yadav, M. Pazoki, and A. Y. Abdelaziz "A comprehensive review of islanding detection methods", *Uncertainties in Modern Power Systems*, pp. 211-256, 2021.
- [11] L. N. Ali, M. F. Tahir, Z. M. S. Elbarbary, M. Z. Yousaf and M. H. Khan "A comprehensive literature review of conventional and modern islanding detection methods", *Energy Strategy Reviews*, Vol. 44, art.no. 101007, 2022.
- [12] I. M. Mainul, M. Nagrial, J. Rizk, and A. Hellany "General aspects, islanding detection, and energy management in Microgrids: a review", *Sustainability*, Vol. 13, No. 16, art.no. 9301, 2021.



Copyright: © 2023 by the authors, Licensee ITEECS, India. This article is an open access article distributed under the terms and conditions of the Creative Commons Attribution (CC BY) license (<https://creativecommons.org/licenses/by/4.0/>).
