

Hybrid Energy Generation System with Brushless Generators

S. Govinda Raju*^{SC}

Abstract: Technical and economic problems are connected with the capacity extension of the grid to remote areas. The discovery and usage of interconnected power production using alternative power supply sources has been promoted. This article proposes a fulfillment using Voltage Source Converter (VSC) and brushless generators with a standalone micro grid topology. The micro grid device is energized with numerous Renewable Energy Sources (RES), including solar PV and wind. However, a Diesel Generator (DG) collection and a Battery Energy Storage System (BESS) are also used to ensure the system's stability. The topology suggested has the benefit of less number of switches and easy power. The structure applied has been fixed as an AC supply by DG. The wind and PV sources are DC sources related to the VSC DC connection. At the DC connection, the BESS is often used to promote the instantaneous equilibrium of power under complex conditions. The VSC further has the potential to alleviate power quality challenges such as harmonics, voltage control and load balancing, in addition to system integration. To illustrate all the capabilities of the proposed method, a good range of Matlab/Simulink yield outcomes are conferred.

Keywords: Microgrid, PMBLDC, Power quality, Voltage regulation, Hybrid Renewable Power Generation

1. Introduction

A wind turbine powers the PMBLDC engine. A Diode Bridge Rectifier (DBR) and DC/DC step converter to the VSC- DC connection connects the WECS. Thanks to trapezoidal back EMF, PMBLDCG is ideally adapted for unregulated rectification. With PMSG, this role is not present because the induced EMF is sinusoidal, so a fluctuating torque is created by the quasi-square wave currents [1]. In addition, the PMBLDC machine's energy density is high, making it compact in scale, making it a good choice for pole placing.

Article History

Received: 18-12-2022;

Revised: 24-01-2023;

Accepted: 25-01-2023;

*Corresponding author: Department of Electrical and Electronics Engineering, Jawaharlal Nehru Technological University, Kakinada, A.P., India.

E-Mail: govind4@gmail.com

Ph: +91-8919930581

Strength assessment of hybrid sources powered device is recorded where the reliability of the wind power production is achieved considering the wind variability and part loss into account. Moreover, by considering diesel, wind and battery, the stability study of the complete device is also conducted [2]. The control of a Wind Energy Conversion System (WECS) dependent Permanent Magnet Synchronous Generator (PMSG) attached to an AC/DC converter through a battery serving as a grid is seen. The energy produced by WECS is passed down to monitor the battery's SOC. In several of the systems mentioned in the literature, the conversion method for changing the speed of wind power operates to derive full strength from the wind [3]. At the operational point, wind energy is received free of charge, so harvesting the optimum power and growing the performance and consumption of WECS is advantageous. Initial capital costs are required, but the fuel is accessible [4]. In such a way to the hill climbing MPPT technique without sensors with the current controlled inverter and the MPPT algorithm without sensors with a boost converter, separate methods for MPPT in WECS are suggested. In addition, for this activity as a voltage

and frequency controller, a control algorithm is necessary to monitor the linked VSC, minimize power quality issues, and combine the dc sources with ac sources [5]. In the literature, several simple control algorithms are mentioned. An advanced composite observer-based control algorithm is being published. To remove harmonic components from every signal, composite observers are used and then the derived basic is further used in this controlling procedure [6]. This article tackles the installation with the BESS of a reduced number of converters of a standalone hybrid energy sources microgrid device with a Synchronous Reluctance Generator (SyRG) and Permanent Magnet Brush Less DC Generator (PMBLDCG). In terms of construction, all these are brush less generators. Using boost converters, PV and wind systems are often run at their maximum energy tracking point. The DG is worked within a defined power variation to maximize the DG's performance [7]. A VSC is suggested to combine the DC supplies through the bidirectional power flow functionality of the AC sources and the potential to increase power efficiency [8]. For WECS, the MPPT approach without mechanical sensors is used; for solar PV devices, an incremental conductance-dependent MPPT approach is suggested.

2. Block diagram of Microgrid

Interconnection of two or more renewable generation sources, such as wind electricity, photovoltaic energy, battery and wind generator, to produce local load power and or to link Hybrid

Energy Systems to grid/micro grid types [9]. The electric output of the solar system and even of the wind system contributes to the strength of integrated production owing to the characteristics of solar energy and wind energy, which is far more related to the power provided by an independent supply. A broad battery bank is needed to draw most power from the wind and photovoltaic array for loading. Being of the growth and introduction of sustainable DC production and the benefit of DC sinks in economic, manufacturing and native recommendations, DC grids have recently resurged. Combining the DC micro grid with the numerous distributed generators was suggested. However before connecting to a DC grid, AC generation needs to be transformed into DC, and DC/AC converters are required for traditional AC utilities [1]. Although, clean energy systems will produce electricity. There is no longer a requirement for HV long-distance transmission. To promote the interaction of green power sources with AC networks, AC Microgrids are proposed. However, the DC yield generation of the photovoltaic (PV) system must be transformed into AC employing DC/DC converters and DC/AC converters wired to an AC utility. In an AC utility, to provide multiple dc voltages, embedded AC/DC and DC/DC structures are required for different household and service facilities [10]. In this article, a hybrid AC/DC micro grid is suggested to eliminate several difficult production processes in single AC or DC grid and to promote the interaction with the power grid of different RES and loads.

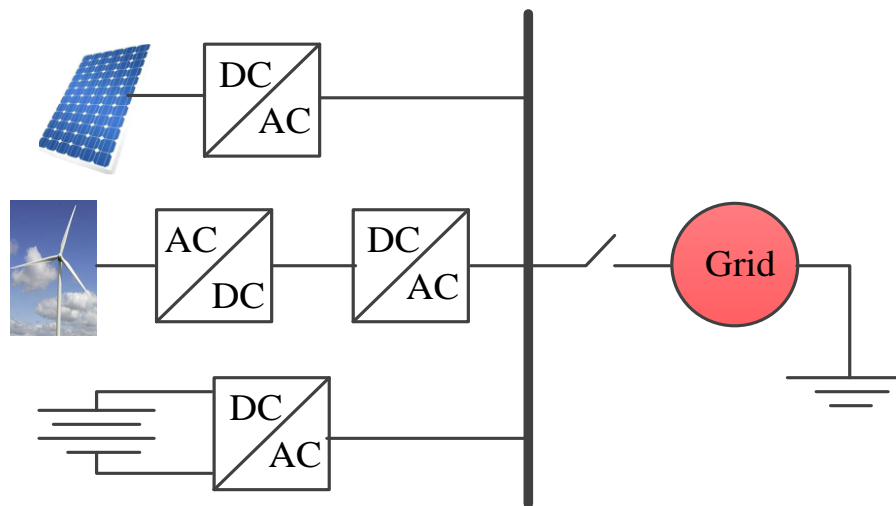

Fig.1: Block diagram of the Microgrid

In order to constrict supply transmission among AC and DC systems and to sustain the reliable functioning of a couple AC and DC utilities for varying generation and requirement conditions until the hybrid utility functions in these grid-integrated and islanding situations, synchronization control schemes between different situations are suggested to belt high energy from RES. The sophisticated power electronics and control systems used would build a far smarter potential grid [2]. Due to solar and wind power's erratic and volatile existence, higher penetration of their forms into established grids may trigger and generate significant technological challenges, especially for poor utilities or independent systems without appropriate and proper repository scope. The effect of the variable existence of PV and WECS will be partly beaten by combining the two sustainable productions into an efficient mix, and the resulting device will become more effective and economical to operate. For all grid connected and standalone networks, voltage and frequency variations and harmonics are significant power quality problems with greater effect in the event of a poor grid. To a large degree, this can be overcome by providing adequate architecture, sophisticated rapid response control equipment, and hybrid device optimization. One of the recent concepts in the power systems subject is the micro grids concept. The micro grid consists of various generating stations and loads. The suggested micro grid consists of wind, solar, Dg and BESS as shown in Fig.1. Each component has advantages and is modeled per the IEEE standards.

3. Hybrid test system modeling

The planned scheme is a standalone microgrid focused on PV-Wind-DG with BESS to supply the regional utilities. The full structure of the device is depicted in Fig. 2. As a DG, a SyRG is used, and as a wind generator, a PMBLDCG. These generators are chosen on purpose [1]. Both of these generators are PMBLDCG and minimize the maintenance expense compared to the brushed models. SyRG is used with a DG more fairly than traditional synchronous production, so the speed controller and AVR requirement is omitted, but the system's frequency and voltage are controlled using VSC. A wind turbine powers the PMBLDC engine [2]. As shown in Fig. 2, the WECS is linked via a DBR and a DC/DC boost

converter at the DC connection of the VSC. Due to trapezoidal back EMF, PMBLDCG is better adapted for unregulated rectification. If a quasi square wave does not provide the winding currents, a minimum distortion torque is created and the system functions neatly. With PMSG, this role is not present because the induced EMF is sinusoidal, so a fluctuating torque is created by the quasi-square wave currents [12]. In addition, the PMBLDC machine's energy density is high, making it compact in scale, making it a good choice for pole placement. The suggested system also involves the solar PV scheme, which is also related to the VSC's dc connection for power transmission to the AC side where weights are available [13]. The BESS is needed, as mentioned previously, to preserve the power settlement and supply honestly. Therefore, a battery bank is also mounted at the dc connection of the VSC.

There are several outlets in the suggested device topology, so an operating approach is built to improve fuel efficiency and increase usable free production extraction. The DG is the single AC source in the device, thus the approach and the end frequency of the load are only connected to the DG's operation [14].

A fixed device frequency indicates the generator's constant velocity (as the generator is SyRG). It is mentioned that the fuel requirement does not differ higher from its figure at full load with the speed service of the diesel engine, rendering the fuel performance of the DG low at lighter loads. With about 80-100 percent loading, diesel engines run relatively well. The control strategy for the DG is established here to always run it within a defined loading margin, as seen in Fig. 3. As there are RES options and a BESS is usable, a DG with a maximum load rating is not needed. A PMBLDC generator, DBR and a boost converter make up the WECS. After the DBR, an inductor is used to make the DC almost steady, which reflects on the ac side as a quasi-square waveform of current, which is useful for PMBLDCG activity as stated earlier. By removing the need for any mechanical MPPT sensor, the function of the WECS is streamlined [15-18]. An MPPT approach is recognized that only includes DC voltage and current sensing. This Control scheme is the equivalent of the disruption and observation algorithm used in solar PV systems for full power extraction.

4. Simulation results

The designed system is simulated using Matlab/Simulink platform. The PV and wind systems operate using MPPT technique, and the DG is worked for only

certain operations described in detail. The outcomes for the fixed speed of the wind system are depicted in Fig. 4 to Fig.7 until $t = 0.05$ s. Wind speed is varied from 7 to 12 m/s at $t = 0.05$ s.

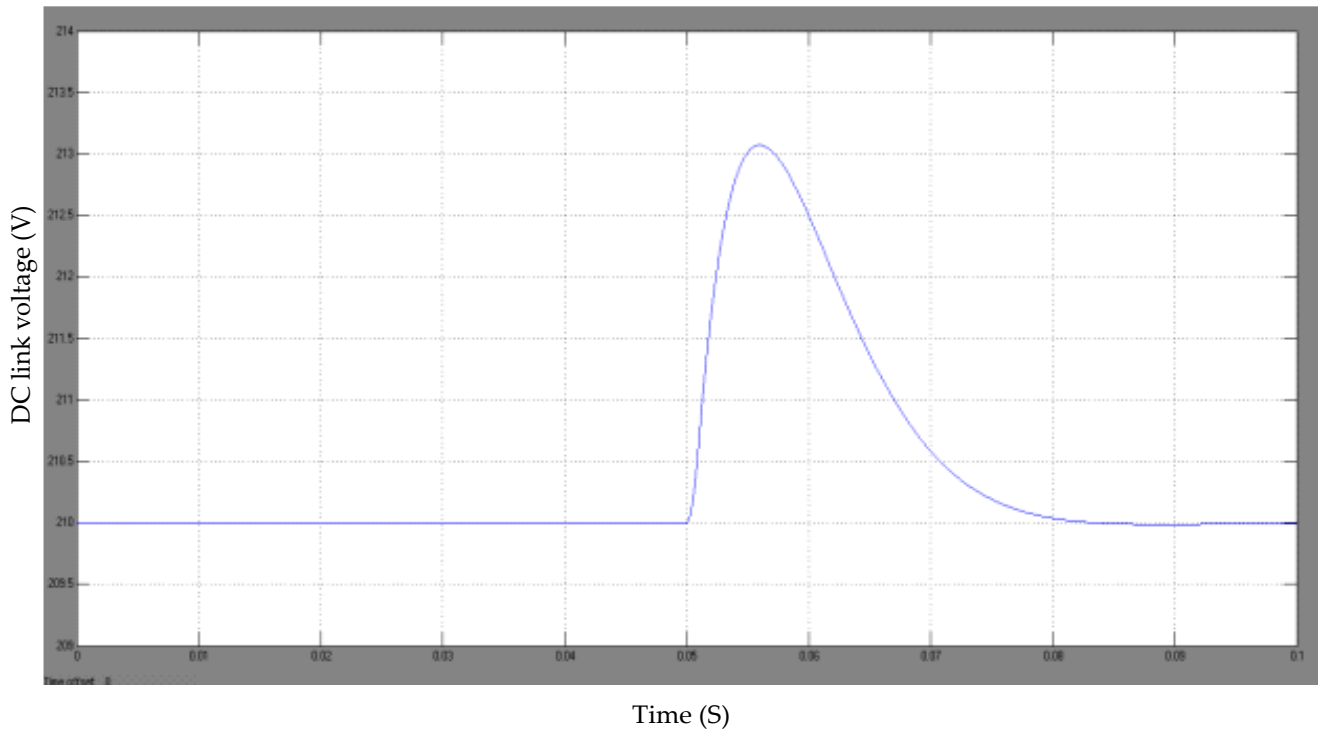

Fig. 4: DC link voltage

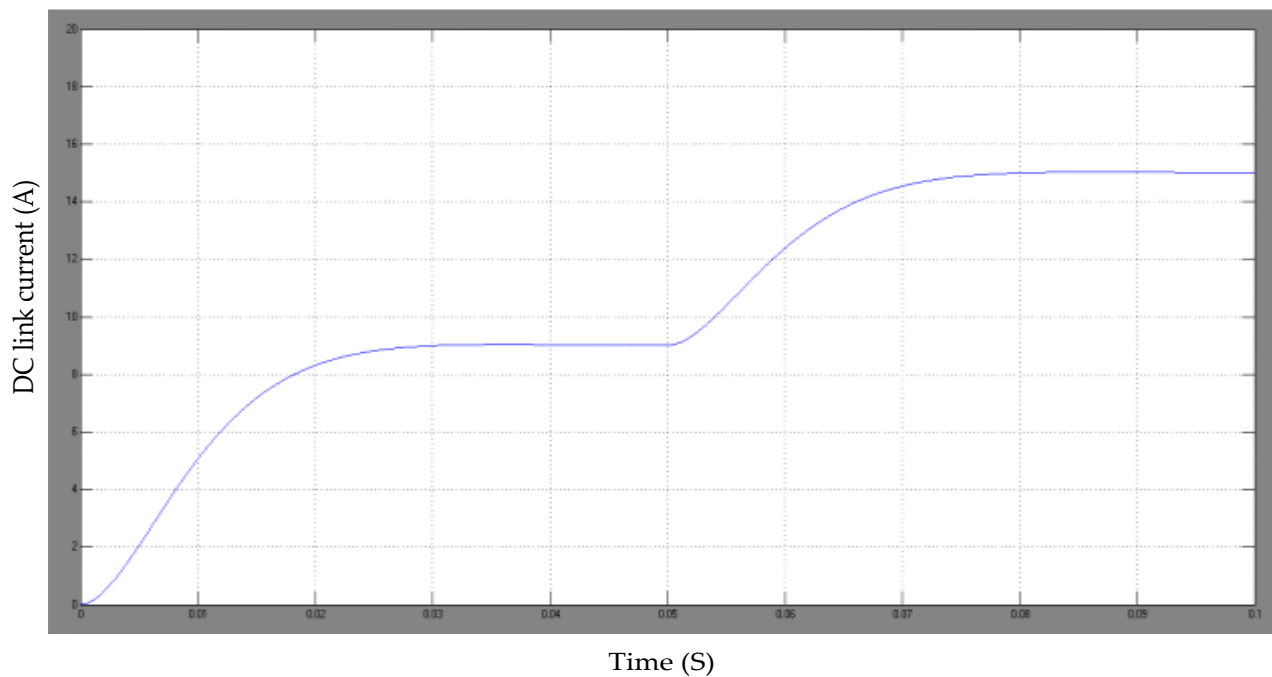

Fig. 5: DC link current

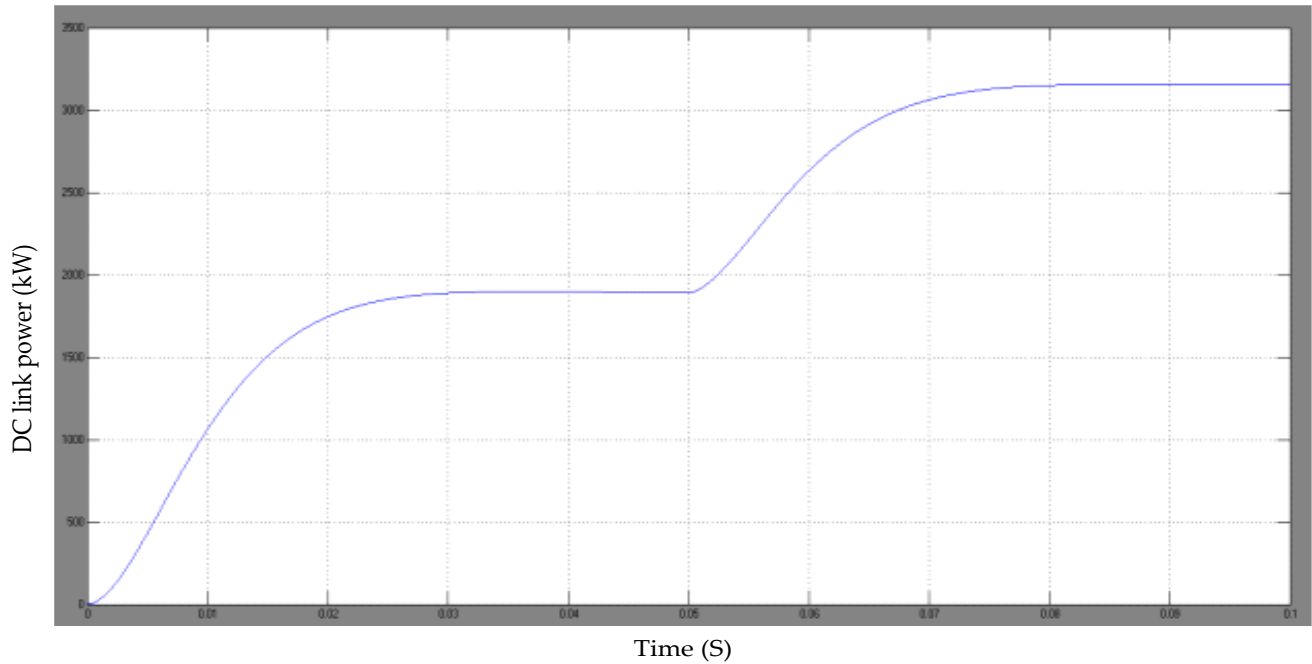

Fig. 6: DC link power

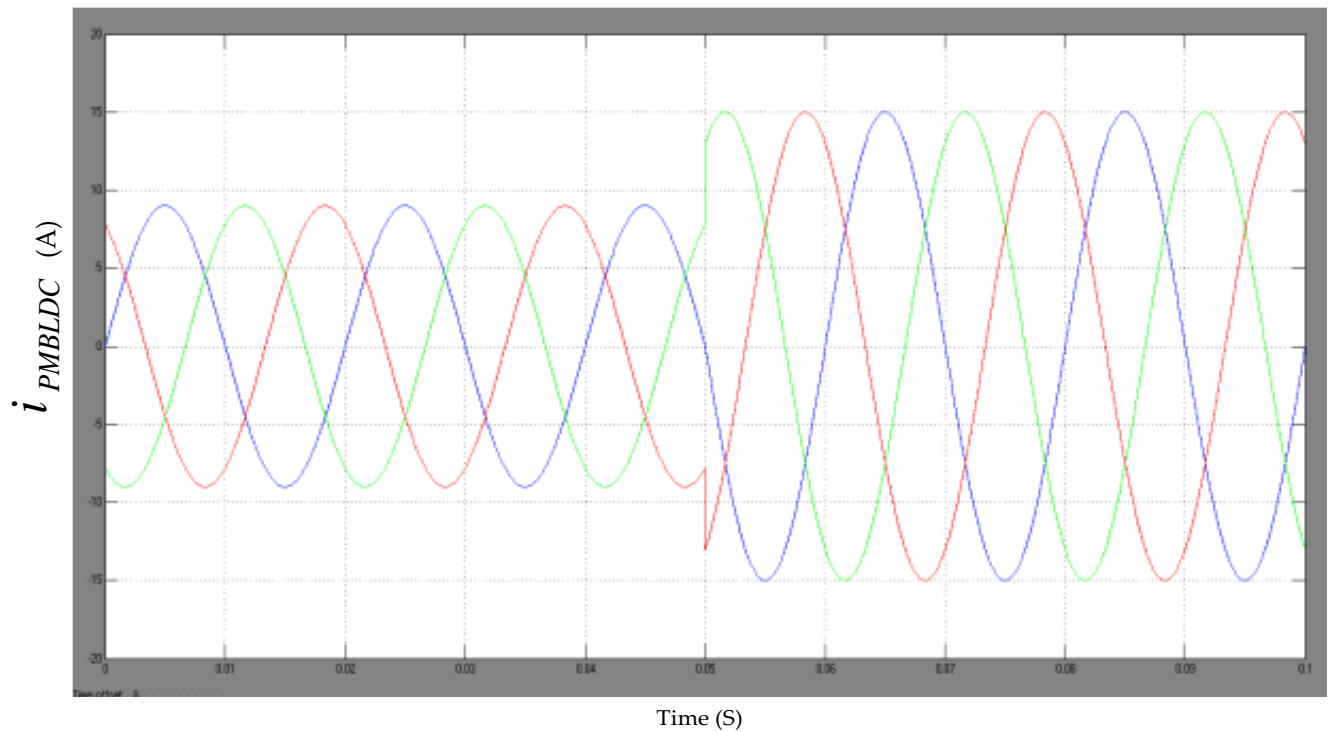

Fig. 7: Current waveform of PMBLDCG

The variations in the speed of the wind system indicate its dynamic behavior. These results indicate that, if the speed of the wind increases it increases the output power of the WECS, which can be observed in the output of the PMBLDCG. This segment briefly discusses how the device would act under such

circumstances of failure. Using a simulation method, fault conditions are generated and evaluated. The first scenario where the ac bus fault is generated is taken. Inside the control algorithm, the current through the converter is regulated.

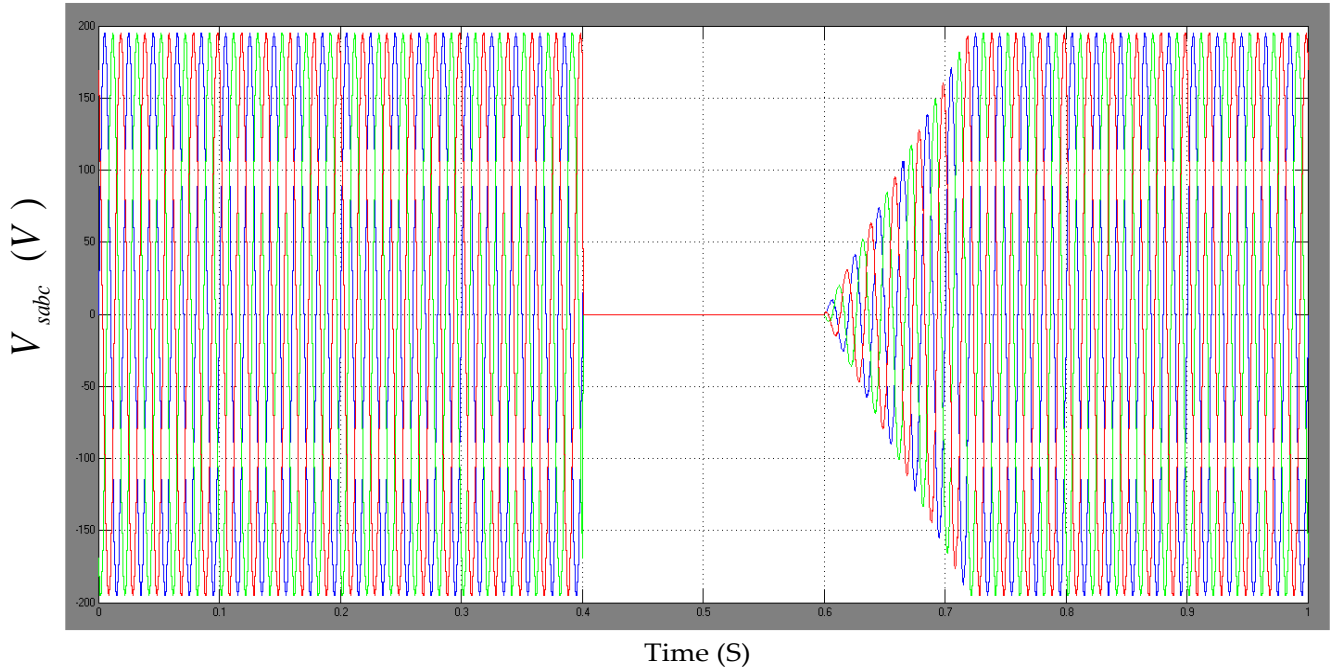

Fig. 8: Source voltage wave forms

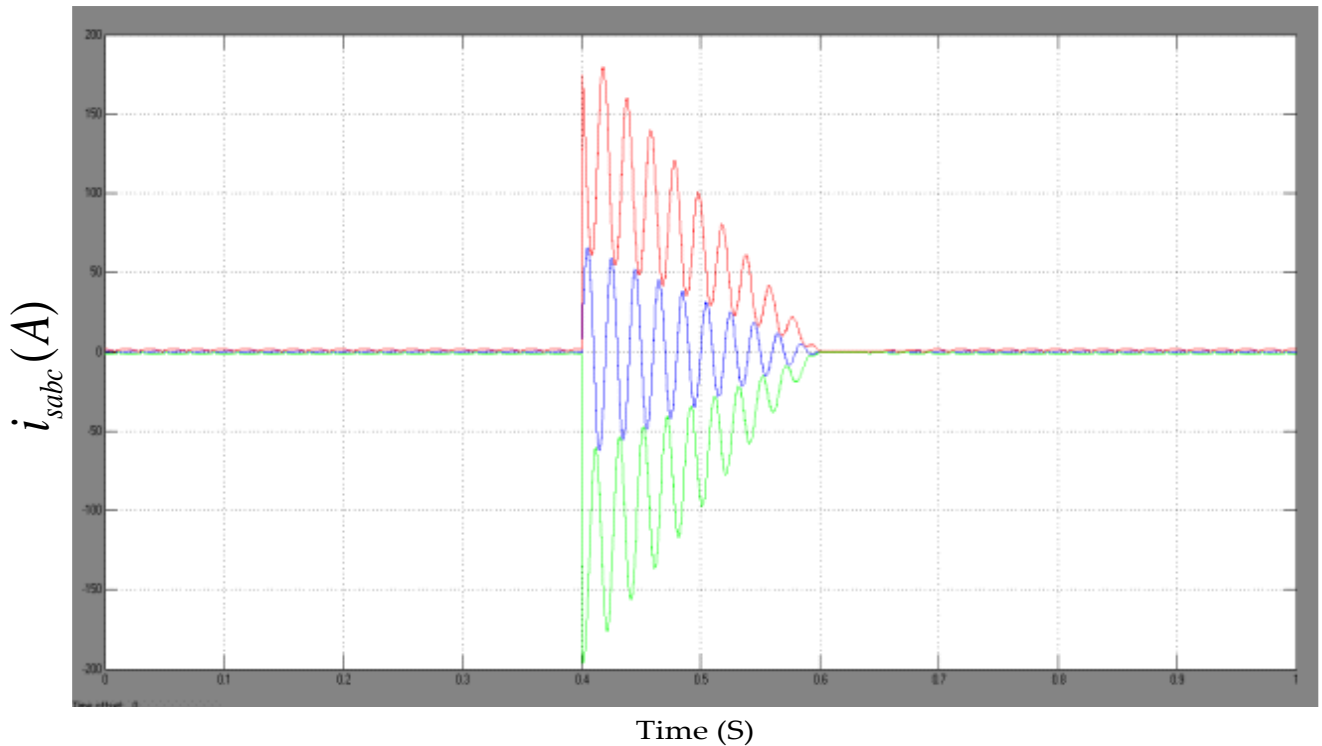

Fig. 9: Source current wave forms

A hard current cap is used to secure the equipment and the machine since the currents are no sinusoidal. If the switching systems provide a safety mechanism, indirect current regulation may be used, requiring only supply currents. These precautions, though are

latchable (the device is shut down), so it is best to restrict the current externally interrupting the process. This is why it uses a direct current regulation that integrates compensator currents.

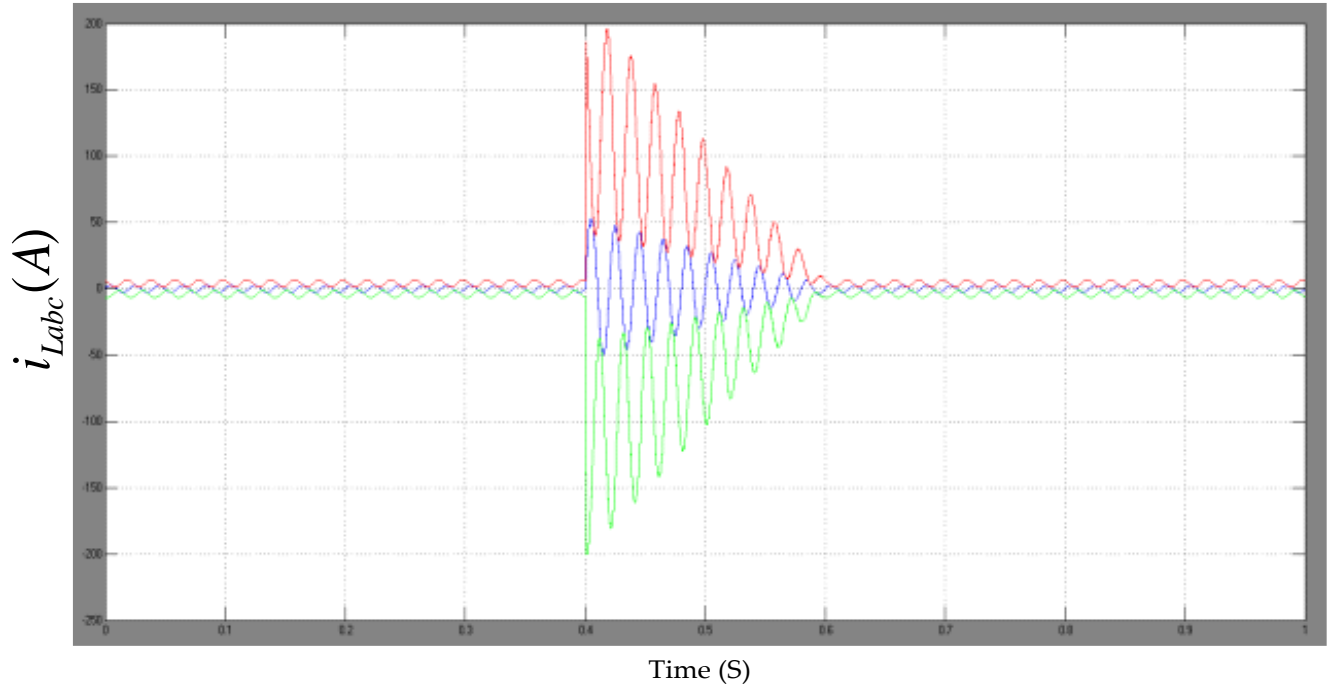

Fig. 10: Load current wave forms

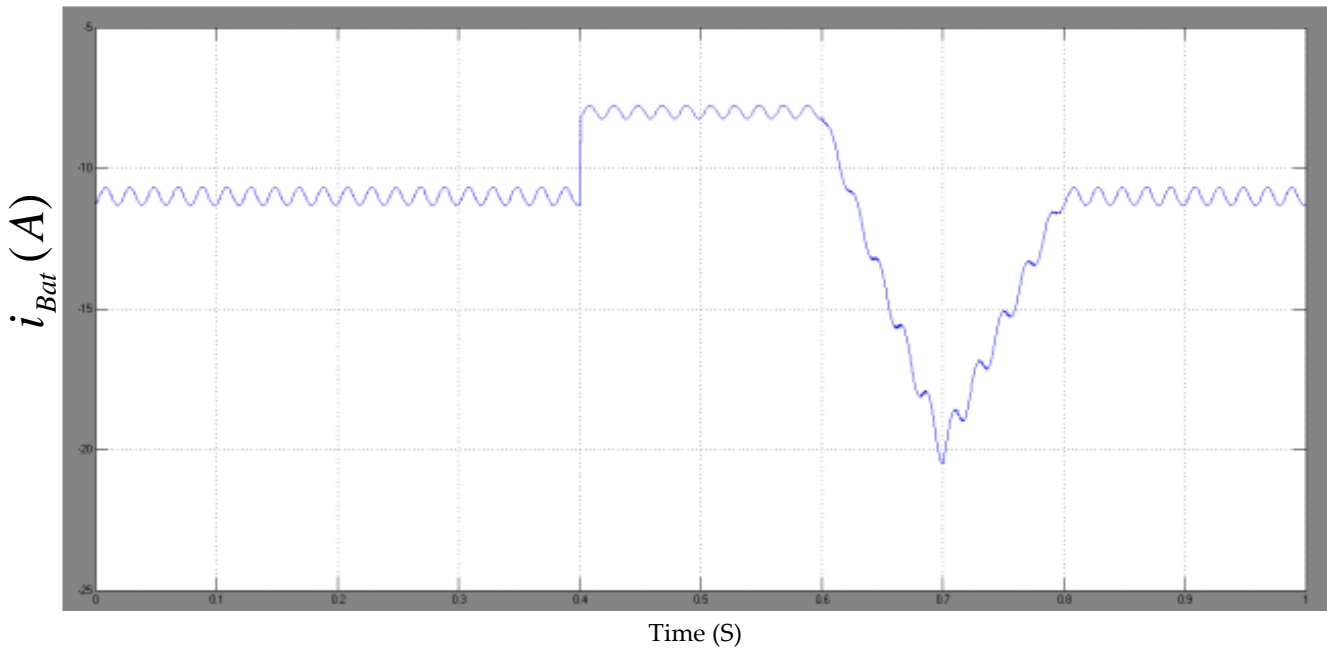

Fig. 11: Battery current

The outcomes are displayed in Fig. 8 to Fig. 12. As depicted in Fig. 8 to Fig. 12, the transformer primarily generates the generator's reactive control support, and the reactive power diverts to the low-impedance fault direction and the voltage of the generator collapses with the fault on the ac side. But the engine picks up

again after the fault is washed up. Another benefit of this design is that it is a machine-based system, and thus the generator contributes greatly to the fault current, which compared to the semiconductor systems has a high short circuit ranking.

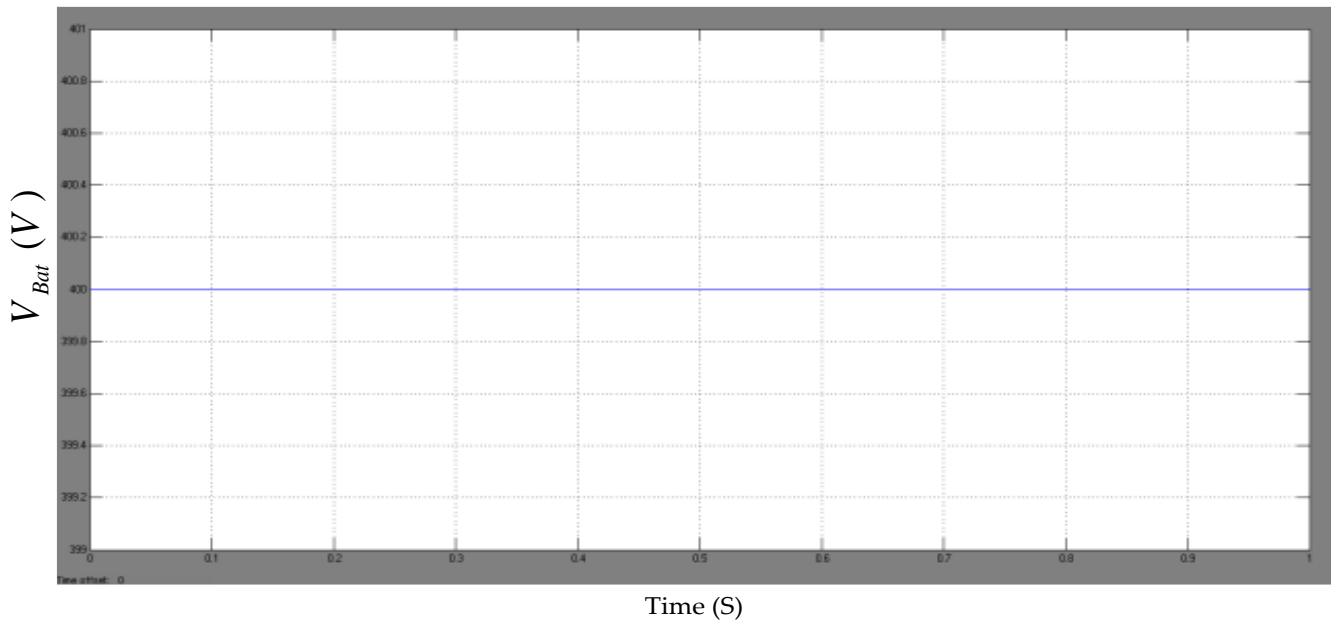

Fig. 12: Battery voltage

5. Conclusion

With better efficiency and power quality, hybrid energy systems will provide environmentally sustainable and cost-effective power techniques. Standalone hybrid-powered sources will provide a good electrical source in remote areas, rather than traditional energy. This is an economic fact to minimize reliance on diesel fuel for off-grid populations. In the event of the unavailability of electrical power from RES, a DG is also provided in the remote hybrid system. In comparison, a hybrid system will greatly minimize the use and pollution of fuel relative to traditional power systems. However, a complicated power controlling technique is needed to receive suitable power control among various sources and maximize the power quality. This thesis uses a short simulation analysis to create a power management approach and control systems for independent hybrid power generation sources. Under different operational conditions, the suggested Microgrids topology with a single VSC and PMBLDCG has been introduced. An adaptive control algorithm operation is often checked under numerous disruptions varying from broad load variance to renewable energy supply instability for device voltage and frequency control elimination of power degradation problems, power control in the entire network. There is also some explanation of the

principle of battery charge-discharge management and fault study. Matlab/Simulink findings have verified the suitability of this structure for remote areas as the system is easy and cost-efficient.

Acknowledgment

The authors are very thankful to the management of JNT University, Kakinada for providing the necessary facilities to carry out this research work.

Conflict of Interest

The authors declare that they do not have any conflict of interest.

References

- [1] K. Krishan, C. Jain, and B. Singh. "A hybrid diesel-wind pv-based energy generation system with brushless generators", *IEEE Transactions on Industrial Informatics*, Vol. 13, No. 4, pp. 1714-1722, 2017.
- [2] M. Akbar, and F. Pourfayaz. "Sizing of standalone photovoltaic/wind/diesel system with battery and fuel cell storage devices by harmony search algorithm", *Journal of Energy Storage*, Vol. 2, pp. 30-42, 2015.
- [3] C. Abbey, Li Wei, and G. Joos "An online control algorithm for application of a hybrid ESS to a wind-diesel system", *IEEE Transactions on*

- Industrial Electronics*, Vol. 57, No. 12, pp. 3896–3904, December 2010.
- [4] T. Hirose and H. Matsuo, "Standalone hybrid wind-solar power generation system applying dump power control without dump load," *IEEE Transactions on Industrial Electronics*, Vol. 59, No. 2, pp. 988–997, Feb 2012.
- [5] W.M. Lin, C.M. Hong, and C.H. Chen "Neural-network-based MPPT control of a standalone hybrid power generation system", *IEEE Transactions on Power Electronics*, Vol. 26, No. 12, pp. 3571–3581, Dec 2011.
- [6] A. Yogiarto, H. Budiono, and I. A. Aditya, "Configuration hybrid solar system (PV), wind turbine, and diesel", *International Conference on Power Engineering and Renewable Energy*, pp. 1–5, Jul 2012.
- [7] D. Yamegueu, Y. Azoumah, X. Py, and N. Zongo, "Experimental study of electricity generation by solar PV/diesel hybrid systems without battery storage for off-grid areas", *Journal of Renewable Energy*, Vol. 36, No. 6, pp. 1780–1787, Jun 2011.
- [8] M. A. Tankari, M. B. Camara, B. Dakyo, and G. Lefebvre "Use of ultra capacitors and batteries for efficient energy management in wind–diesel hybrid system", *IEEE Transactions on Sustainable Energy*, Vol. 4, No. 2, pp. 414–424, Apr 2013.
- [9] D. C. Das, A. K. Roy, and N. Sinha "GA based frequency controller for solar thermal-diesel-wind hybrid energy generation/energy storage system", *International Journal of Electrical Power and Energy Systems*, Vol. 43, No. 1, pp. 262–279, Dec 2012.
- [10] F. Bonanno, A. Consoli, A. Raciti, B. Morgana, and U. Nocera "Transient analysis of integrated diesel-wind-photovoltaic generation systems", *IEEE Transactions on Energy Conversion*, Vol. 14, No. 2, pp. 232–238, Jun 1999.
- [11] L. Xu, S. Islam, A.A. Chowdhury, and D.O. Koval, "Reliability evaluation of a wind-diesel-battery hybrid power system", *IEEE/IAS Industrial and Commercial Power Systems Technical Conference*, pp. 1–8, May 2008.
- [12] J. De Matos, F. E. Silva, and L. Ribeiro "Power control in AC isolated microgrids with renewable energy sources and energy storage systems", *IEEE Transactions on Industry Electronics*, Vol. 62, No. 6, pp. 3490–3498, Jun 2015.
- [13] R-J Wai, C. Y. Lin, and Y. R. Chang, "Novel maximum-power-extraction algorithm for PMSG wind generation system", *IET Electric Power Applications*, Vol. 1, No. 2, pp. 275–283, Mar 2007.
- [14] K. Tan and S. Islam "Optimum control strategies in energy conversion of PMSG wind turbine system without mechanical sensors", *IEEE Transactions on Energy Conversion*, Vol. 19, No. 2, pp. 392–399, Jun 2004.
- [15] Z. M. Dalala, Z. U. Zahid, W. Yu, Y. Cho, and J.S. Lai, "Design and analysis of an MPPT technique for small-scale wind energy conversion systems", *IEEE Transactions on Energy Conversion*, Vol. 28, No. 3, pp. 756–767, Sep. 2013.
- [16] Z. Zhuoran, J. Li, Y. Liu, X. Yanwu and Y. Yan "Overview and development of variable frequency AC generators for more electric aircraft generation system", *Chinese Journal of Electrical Engineering*, Vol. 3, No. 2, pp. 32-40, 2017.
- [17] L. Yi, W. Xu, J. Zhu, and F. Blaabjerg. "Sensorless control of standalone brushless doubly fed induction generator feeding unbalanced loads in a ship shaft power generation system", *IEEE Transactions on Industrial Electronics*, Vol. 66, No. 1, pp. 739-749, 2018.
- [18] H. Huerta and A. Loukianov "Energy based sliding mode control of Brushless Double-fed Induction Generator", *International Journal of Electrical Power and Energy Systems*, Vol. 130, pp. 107002, 2021.



Copyright: © 2023 by the authors, Licensee ITEECS, India. This article is an open-access article distributed under the terms and conditions of the Creative Commons Attribution (CC BY) license (<https://creativecommons.org/licenses/by/4.0/>).
